

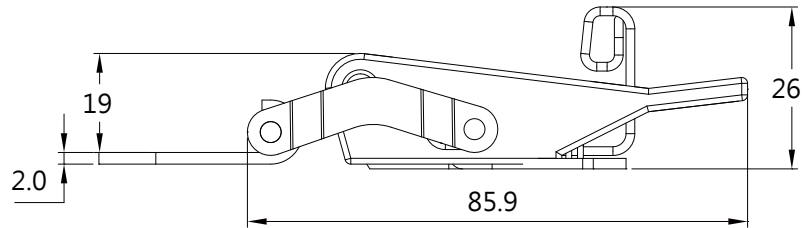

TSL-605 不鏽鋼彈簧迫緊式搭扣 Stainless Steel Spring Loaded Draw Latch

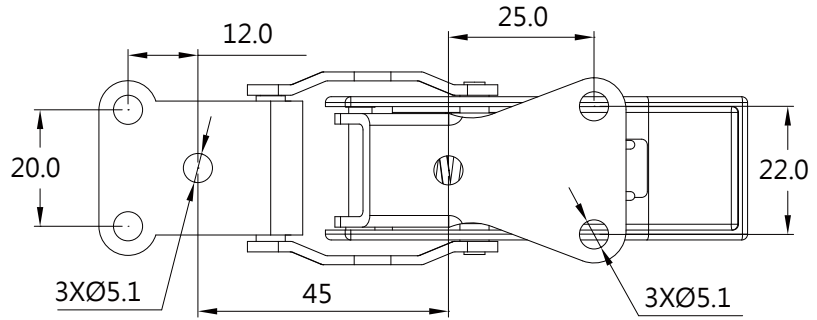

特點 Feature

內置彈簧設計可補償設計上或是震動所產生的間隙並迫緊物件
Internal spring loaded design compensates for tolerance and vibrations.

產品型號 Item No.	材質 Material	表面處理 Finish
TSL-605	不鏽鋼 304 Stainless Steel 304	震動研磨 Vibration Grind



TSL-3061 不鏽鋼彈簧迫緊式搭扣 Stainless Steel Spring Loaded Draw Latch

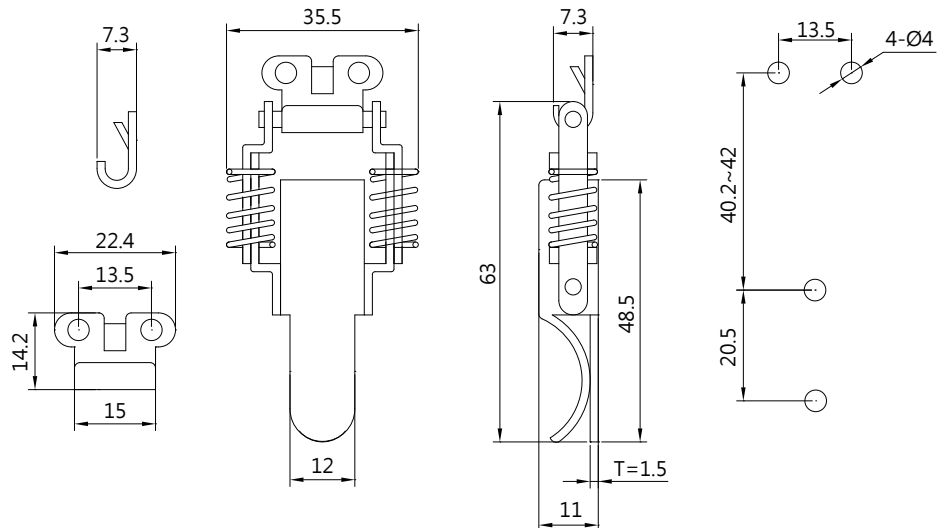

特點 Feature

外裝式彈簧設計可補償設計上或是震動所產生的間隙並迫緊物件。可提供穩定的鎖閉力道。
External spring loaded design compensates for tolerance and vibrations. Provides constant hold tension for secure latching.

產品型號 Item No.	材質 Material	表面處理 Finish
TSL-3061	不鏽鋼 304 Stainless Steel 304	震動研磨 Vibration Grind