

Griffserie ST

Qualitäts-Griffe mit zentrischen Gewindebohrungen.

Werkstoff und Oberfläche:
Rundstahl. Oberfläche feinstgeschliffen und hochglanzverchromt.
Einschließlich chromfarbenen Messing-Abschlusscheiben.

Tragkraft:
min. 1.000 N.

Hinweis:
Andere Abmessungen auf Anfrage.

Ab einer Mindestbestellmenge von 100 Stück/Grifftyp auch mit mattverchromter Oberfläche lieferbar.

Handle Series ST

Quality handles with centered tapped bores.

Material and surface:
Round steel bar. Precision ground and high gloss chromium plated surface. Including chromium coloured brass cover washers.

Stress resistance:
min. 1.000 N.

Note:
Other dimensions on request. Also available with matt chromium plated surface for minimum order quantities of 100 pieces/handle type.

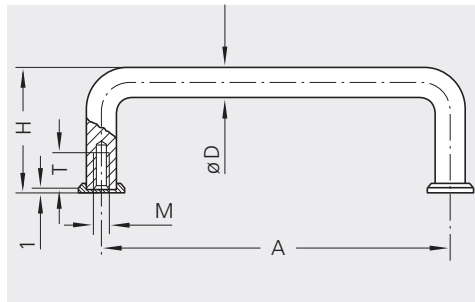

A	Bestell-Nr. Order no.	Ø D	H	M	T
32	ST-05.032.22	5	21		
42	ST-05.042.22				
55	ST-05.055.22				
76	ST-05.076.22	5	25	3	6
88	ST-05.088.22				
32	ST-08.032.22				
55	ST-08.055.22				
64	ST-08.064.22				
88	ST-08.088.22				
96	ST-08.096.22	8	33	4	8
98	ST-08.098.22				
102	ST-08.102.22				
120	ST-08.120.22				
128	ST-08.128.22				
136	ST-08.136.22				
55	ST-10.055.22				
88	ST-10.088.22				
100	ST-10.100.22				
102	ST-10.102.22				
115	ST-10.115.22				
120	ST-10.120.22	10	41	5	10
136	ST-10.136.22				
180	ST-10.180.22				
200	ST-10.200.22				
235	ST-10.235.22				
250	ST-10.250.22				

Werkbild: Rohde
Rund-Stahlgriffe Typ ST im Galvanoautomat nach dem Vernickeln
Picture made by: Rohde
Round steel rod handles typ ST after nickel plating in the automatic electroplating plant