

Miniature Metal Bellows Coupling

with collet clamps

optional  
laserwelded  
optional full stainless  
steel version

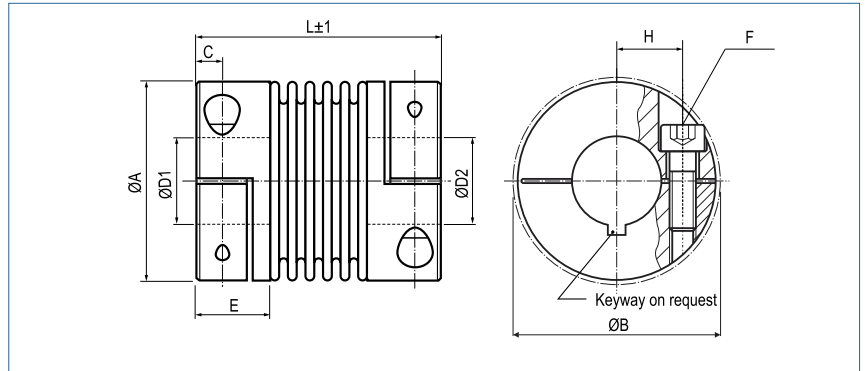

Order Code

**KB2 / 45 - 50 - 10 - 16 - (S)**

Type / Size                      Length L                      ØD1 (H7)                      ØD2 (H7)                      Options

Size	Torque TKN (Nm)	Dimensions (mm)								Technical Data							
		L	Ø A	D1/D2	H	C	Ø B	E	F	Mass (g)	Moment of Inertia J (g cm <sup>2</sup> )	Spring Stiffness			Misalignment		
		Length	Outer Ø	Bore Sizes (H7) min-max				Hub-length	Screw (ISO4762) TA (Nm)			torsional CT (Nm/rad)	radial CR (N/mm)	axial CA (N/mm)	radial ΔKr (mm)	axial ΔKa (mm)	angular ΔKw (°)
1	0.1	25	10	1-4	3.4	2	11	7	M1.6	3	0.5	65	10	14	0.12	0.2	1.2
		0.1															
5	0.5	21	15.5	3-8	5.2	2.5	17.5	7	M2	7.5	2.7	260	43	13	0.1	0.2	1
		25		8#					7.8	2.8	200	18	10	0.15	0.3	1.5	
		28							8.2	3	160	9	8	0.2	0.4	2	
10	1	23	15.5	3-8	5.2	2.5	17.5	7	M2	9	3.1	510	74	27	0.1	0.2	1
		26		8#					9.3	3.4	380	31	20	0.15	0.3	1.5	
		31							10	3.7	310	16	16	0.2	0.4	2	
15	1.5	26	20	3-10	7	3	21	8,5	M2.5	13	8	750	59	15	0.1	0.3	1.5
		31		10#					0.85	15	9.3	700	20	9	0.15	0.4	2
20	2	32	25	3-14	9	3.5	27	11	M3	29	24	1500	67	12	0.15	0.3	1.5
		38		14#					32	27	1300	21	11	0.2	0.4	1.5	
		42							2	33	29	1050	11	9	0.25	0.5	2
45	4.5	41	32.5	6-18	12	5	34	13	M4	61	100	6500	168	32	0.1	0.3	1.5
		50		18#					3.5	67	112	4200	41	20	0.2	0.5	2
100	10	47	40.5	6-25	15.5	5	41.5	13,5	M4	86	233	8100	120	27	0.15	0.4	1.5
		57		25#					4.5	106	290	6800	29	17	0.3	0.6	2

<b>Speed</b>	max. 15000 min <sup>-1</sup>
<b>Material</b>	bellows - stainless steel hub - aluminium
<b>Hub</b>	bore tolerance: H7
<b>Temperature Range</b>	-30 °C ~ 120 °C
<b>Keyway</b>	optional acc. DIN 6885 biggest bore marked with a #