

Miniature Metal Bellows Coupling

with split hubs

optional
laserwelded
optional full stainless
steel version

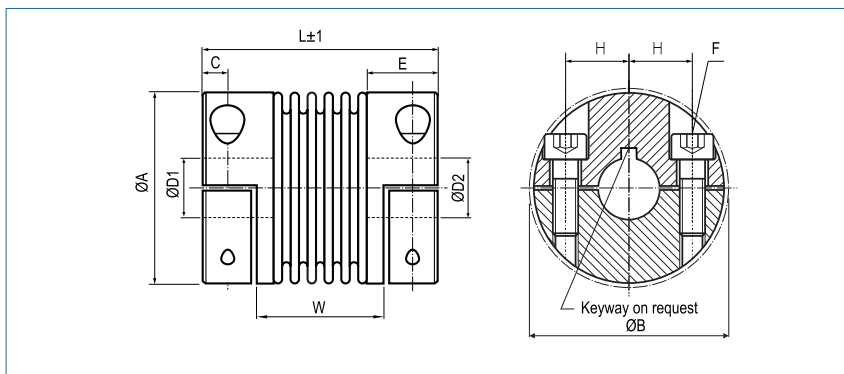

Order Code

KB2H / 45 - 50 - 10 - 16 - (S)

Type / Size

Length
L

ØD1
(H7)

ØD2
(H7)

Options

Size	Torque TKN (Nm)	Dimensions (mm)									Technical Data							
		L	Ø A	D1/D2	H	C	ØB	E	W	F	Mass (g)	Moment of Inertia J (g cm ²)	Spring Stiffness			Misalignment		
		Length	Outer Ø	Bore Sizes (H7) min~max				Hub- length		Screw (ISO4762) TA (Nm)			torsional CT (Nm/rad)	radial CR (N/mm)	axial CA (N/mm)	radial ΔKr (mm)	axial ΔKa (mm)	angular ΔKw (°)
5	0.5	21	15.5	3-8	5.2	2.5	17.5	7	12	M2	7.5	2.7	260	43	13	0.1	0.2	1
		16							0.43	7.8	2.8	200	18	10	0.15	0.3	1.5	
		19								8.2	3	160	9	8	0.2	0.4	2	
10	1	23	15.5	3-8	5.2	2.5	17.5	7	14	M2	9	3.1	510	74	27	0.1	0.2	1
		17							0.43	9.3	3.4	380	31	20	0.15	0.3	1.5	
		22		10						3.7	310	16	16	0.2	0.4	2		
15	1.5	26	20	3-10	7	3	21	8,5	14.4	M2.5	13	8	750	59	15	0.1	0.3	1.5
		31		10#					19.4	0.85	15	9.3	700	20	9	0.15	0.4	2
20	2	32	25	3-14	9	3.5	27	11	18.4	M3	29	24	1500	67	12	0.15	0.3	1.5
		24.4							2	32	27	1300	21	11	0.2	0.4	1.5	
		28.4		33						29	1050	11	9	0.25	0.5	2		
45	4.5	41	32.5	6-18	12	5	34	13	24	M4	61	100	6500	168	32	0.1	0.3	1.5
		33		3.5					67	112	4200	41	20	0.2	0.5	2		
100	10	47	40.5	6-25	15.5	5	41.5	13,5	29	M4	86	233	8100	120	27	0.15	0.4	1.5
		39		4.5					106	290	6800	29	17	0.3	0.6	2		

Speed	max. 15000 min ⁻¹
Material	bellows - stainless steel hub - aluminium
Hub	bore tolerance: H7
Temperature Range	-30 °C ~ 120 °C
Keyway	optional acc. DIN 6885 biggest bore marked with a #