

No. 6803

Vertical acting toggle clamp

with open clamping arm and angle base.

Galvanized and passivated. Rivets made of stainless steel, which, for sizes 2 and 3, run in hardened bushings.

Bearings are pre-lubricated.

Ergonomic, oil-resistant handle with large grip surface and soft components. Safety clamping piece with finger protection. Lock washer for the thrust bolt at the end of the clamping arm.

Complete with tempered, galvanized clamping screw no. 6890.



Order no.	Size	F1 [kN]	F2 [kN]	Clamping screw	Weight [g]
90316	1	0,8	1,1	M5x30	125
90324	2	1,0	1,2	M6x35	220
90332	3	1,4	2,5	M8x45	400
90340	4	2,0	3,0	M8x65	650

Also available in „STAINLESS STEEL“ version (no. 6803NI).

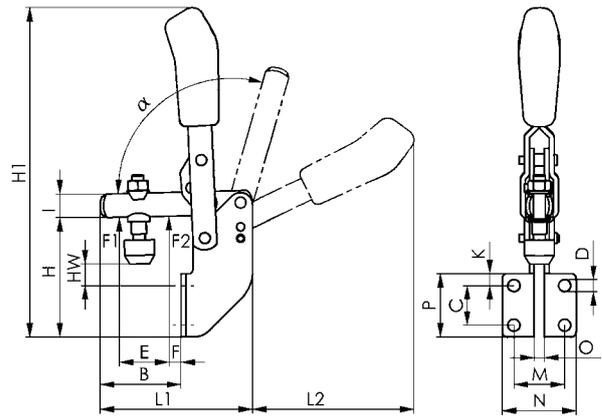

Recommendations



No. 6895,
page 113



No. 6896,
page 112



No. 6803S,
page 41

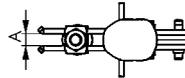

Dimensions:

Order no.	Size	A	B	C	D	E	F	H	H1	HW min.	HW max.	I	K	L1	L2	M	N	O	P	α	α^*
90316	1	5	34,5	14	4,5	18	7	45	125	2,5	9,0	10	10	61	58	20,0	30,0	5	30	98°	-
90324	2	6	41,0	20	6,1	25	6	60	167	7,5	15,5	12	6	77	81	25,5	37,0	5	32	105°	60°
90332	3	8	63,0	24	6,5	37	11	71	223	9,0	17,5	18	7	111	112	28,5	42,5	6	38	105°	60°
90340	4	10	84,0	32	8,5	54	11	102	280	11,0	40,0	20	54	141	129	32,0	52,0	8	96	105°	60°

* The opening angle can be changed by pressing in a stop pin.



Subject to technical alterations.