

No. 6830NI

Horizontal acting toggle clamp

with open clamping arm and horizontal base.

Stainless steel, polished. In sizes 2 to 5, rivets run in bearing bushes. Bearings are pre-lubricated. Ergonomic, oil-resistant handle with large grip surface and soft components.

Supplied complete with stainless clamping screw no. 6890NI.

Also suitable for use in the food industry.



CAD

Order no.	Size	F1 [kN]	F2 [kN]	Clamping screw	Weight [g]
95141	0	0,25	0,4	M4x25	35
95166	1	0,80	1,1	M5x30	105
95182	2	1,00	1,2	M6x35	185
95208	3	1,80	2,5	M8x45	320
95224	4	2,00	3,0	M8x65	700

Note:

For suitable sensor monitor for size 3 see no. 6897S.

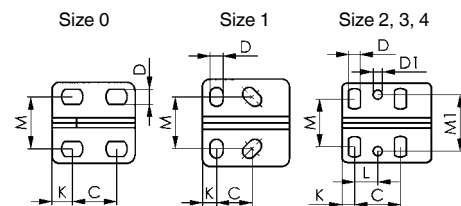
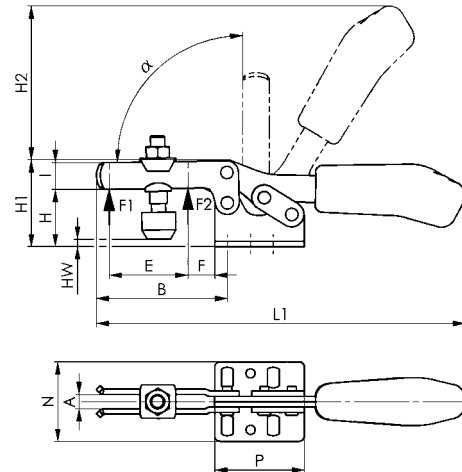

Recommendations



No. 6897S,
page 106



No. 6800NI,
page 47



No. 6847KNI,
page 53

Dimensions:

Order no.	Size	A	B	C	D	D1	E	F	H	H1	H2	HW min.	HW max.	I	K	L	L1	M	M1	N	P	α
95141	0	4	28	11,5-15,5	4,6	-	9,0	5	14,5	23,0	34	-5,0	0,6	7,5	6,25	-	79	16,0	-	25,0	25,5	90°
95166	1	5	42	13,3-14,7	5,2	-	18,6	8	19,0	30,0	49	-4,0	2,0	10,0	5,50	-	120	18,0-21,5	-	34,0	34,0	90°
95182	2	6	64	26,0	5,6	5,6	32,0	16	24,0	45,0	68	-1,6	5,0	13,0	6,00	12,7	162	19,5-29,5	28,5	42,0	38,0	90°
95208	3	8	73	25,7	6,5	5,1	36,0	14	32,0	48,5	86	-2,0	9,0	15,0	7,00	13,0	206	22,0-31,8	31,6	44,5	50,0	90°
95224	4	10	113	41,0	8,5	8,5	63,0	27	45,0	75,0	126	-4,0	24,0	20,0	8,00	20,5	287	29,0-43,0	43,0	58,0	57,0	90°