

1 Type

- Operation
- DK** with triangular spindle (DK7)
 - VK7** with square spindle A/F7
 - VK8** with square spindle A/F8
 - SCH** with slot
 - VDE** with double bit
 - SG** with star knob
 - SK** with wrench
 - ST** with T-Handle
 - RG** with knurled knob GN 7336
 - KG** with wrench
 - HG** with lever

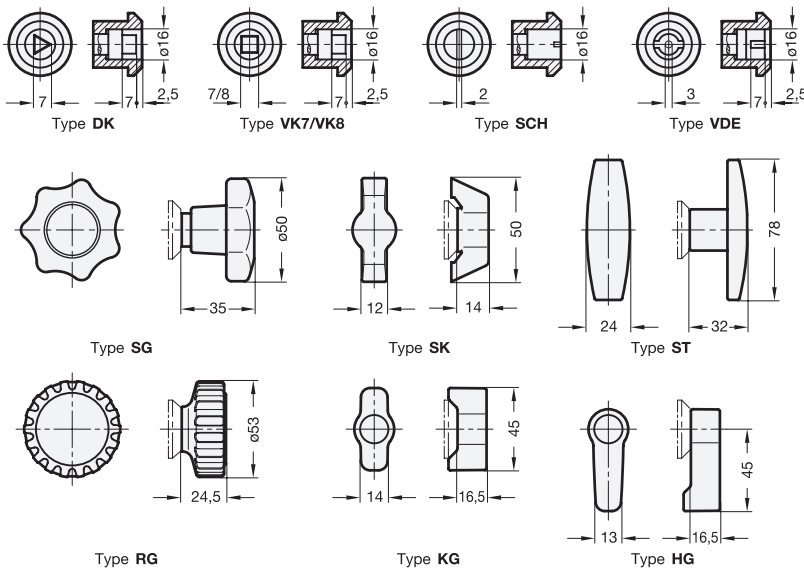

2

Latch distance A											d		h			
	4	8	13	16	20	24	28	32	36	40	45	Type DK, VK7, VK8, VDE, SCH, SG, RG, KG, HG	Type SK, ST	Type DK, VK7, VK8, VDE, SCH, SG, RG, KG, HG	Type SK, ST	
4	8	13	16	20	24	28	32	36	40	45	28	32	4	6		
6	10	14	18	22	26	30	34	38	42	50	28	32	4	6		

Specification

- Lock housing
Zinc die casting
- Locating ring
- chrome plated (Standard) —
- plastic coated
black, RAL 9005, textured finish ● **SW**
- All other parts
Steel zinc plated, blue passivated
- Operation handles
Plastic (Polyamide PA)
black, matt
- Cover cap (type RG, KG, HG)
light grey
- RoHS compliant

3

Information

Latches GN 115 lock by a turning operation limited to 90° which moves the locking behind the door frame. The bevels of the latch ease the closing of the door.

Latches with 22 different cranks cover a latch distance A from 4 to 50 mm.

Latches GN 115 are supplied with loosely enclosed locking.

see also...

- *Stainless Steel-Latches GN 115* → Page 862

<p>Latch, chrome plated locating ring</p> <p>GN 115-VK-20</p>	1	Type
	2	Latch distance A
<p>Latch, black locating ring</p> <p>GN 115-SG-32-SW</p>	1	Type
	2	Latch distance A
	3	Finish