

1 Type

- Operation with
- SG** star knob
- SK** wing knob
- ST** T-Handle
- RG** knurled knob GN 7336
- KG** wing knob
- HG** lever
- LG** hand lever (only with locating ring in SW)

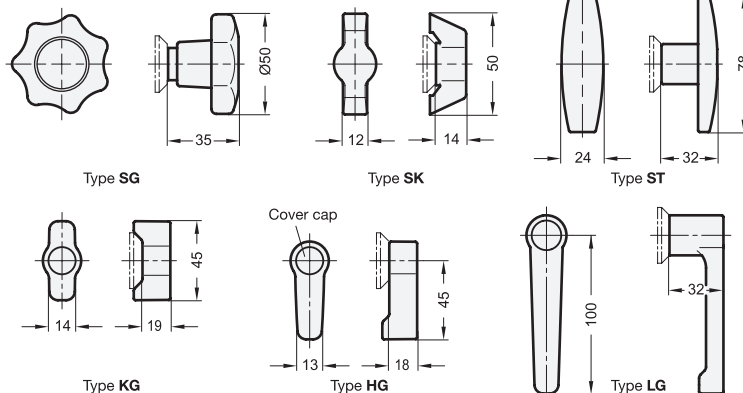

2

Latch distance A											d		h	
											Type SG, RG, KG, HG	Type SK, ST, LG	Type SG, RG, KG, HG	Type SK, ST, LG
4	8	13	16	20	24	28	32	36	40	45	28	32	4	6
6	10	14	18	22	26	30	34	38	42	50	28	32	4	6

Specification

- Lock housing
Zinc die casting
- Locating ring
- chrome plated (Standard) —
- plastic coated
black, RAL 9005, textured finish ● **SW**
- All other parts
Steel zinc plated, blue passivated
- Operating elements
- Plastic (Polyamide PA)
black, matte
(Type SG, SK, ST, RG, KG, HG)
- Zinc die casting
plastic coated
black, RAL 9005, textured finish
(Type LG)
- Cover cap (Type RG, KG, HG, LG)
Plastic (Polyamide PA)
light grey
- *Plastic characteristics* → Page 1483
- **RoHS compliant**

3

Information

Latches GN 115 lock by a turning operation limited to 90° which moves the locking behind the door frame. The bevels of the latch ease the closing of the door.

Latches with different cranks cover a latch distance A from 4 to 50 mm.

Latches GN 115 are supplied with loosely enclosed latch.

see also...

- *List of latch types* → Page 892 ff.
- *Latches GN 115 (operation with key)* → Page 898
- *Latches GN 115 (lockable)* → Page 899
- *Stainless Steel-Latches GN 115* → Page 900 ff.

How to order (chrome plated locating ring)

1	Type
2	Latch distance A

GN 115-SG-20

How to order (black locating ring)

1	Type
2	Latch distance A
3	Finish

GN 115-HG-32-SW