

Fork head DIN 71752

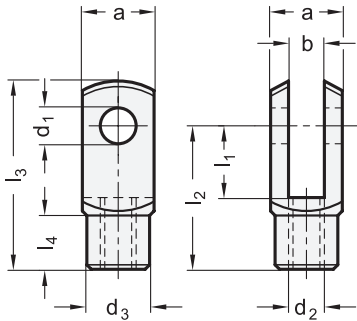

Fork joints GN 751

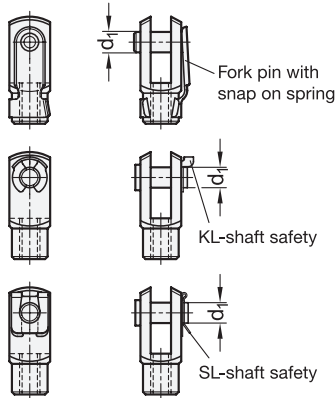

- 4 Type**
- B** Snap on spring pin
 - KL** Pin with side mount ring
 - SL** Pin with safety clip (only for $d_1 = 4...16$)

d ₁ H9/h11	l ₁	d ₂	Thread		a	b	d ₃	l ₂	l ₃	l ₄		
			Left hand thread	Fine thread								
4	8	16*	M 4	-	8	4	8	16	24	21	29	6
5	10	20	M 5	M 5L	10	5	9	20	30	26	36	7,5
6	12	24	M 6	M 6L	12	6	10	24	36	31	43	9
8	16	32	M 8	M 8L	M 8F = M 8 x 1	8	14	32	48	42	58	12
10	20	40	M 10	M 10L	M 10F = M10 x 1,25	10	18	40	60	52	72	15
12	24	48	M 12	M 12L	M 12F = M12 x 1,25	12	20	48	72	62	86	18
14	28	56	M 14	M 14L	M 14F = M14 x 1,5	14	24	56	85	72	101	22,5
16	32	64	M 16	M 16L	M 16F = M16 x 1,5	16	26	64	96	83	115	24
20*	40	-	M 20	M 20L	-	20	34	80	-	105	-	30

* Type B is not available from stock

Specification

- Steel
 - Tensile strength class 5
 - zinc plated, blue passivated
- Shaft safetys
 - spring sheet metal
 - hardened and tempered
 - zinc plated, blue passivated
- *Strength values of nuts* → Page 1481
- *ISO-Fundamental tolerances* → Page 1479
- **RoHS compliant**

On request

- Fork heads in accordance with DIN 71752 with $d_1 = 25, 30, 35, 42$ and 50

Information

Fork joints GN 751 consists of a fork head according DIN 71752 and a fork pin with KL-shaft (Type KL and SL) a fork pin with snap-on spring (Type B).

Size $d_1 = 12$ is supplied with a fine thread M12x1,5 according to DIN. In practice, however, M12x1,25 is preferred. Standard DIN 71752 does not foresee size $d_1 = 20$.

see also...

- *Stainless Steel-Fork joints GN 751* → Page 1162
- *Fork joints (Aluminum) GN 751* → Page 1163

How to order (with pin)	1	d ₁
	2	l ₁
	3	d ₂
	4	Type
GN 751-10-20-M10-B		

How to order (without pin)	1	d ₁
	2	l ₁
	3	d ₂
DIN 71752-10-40-M10L		