

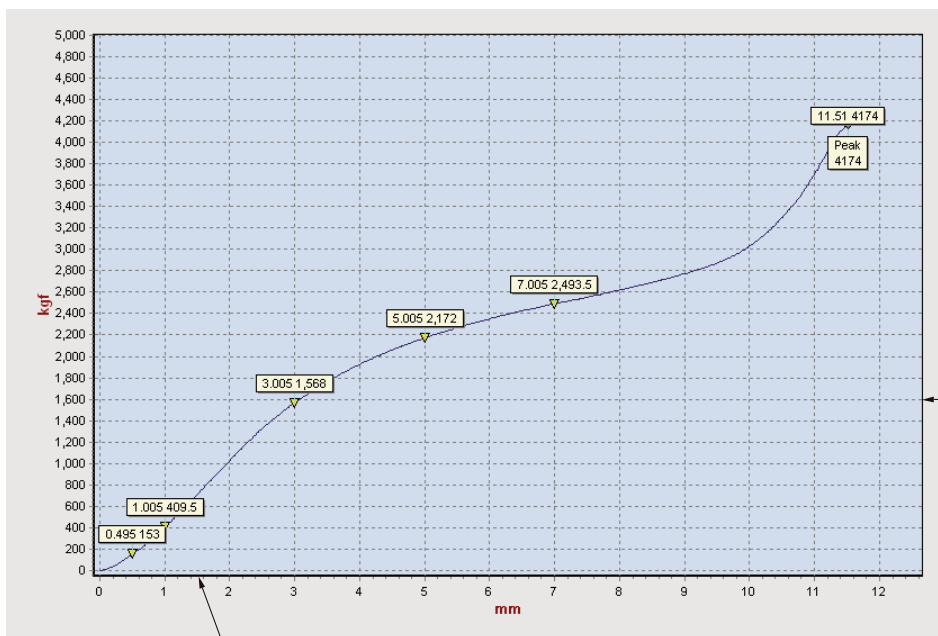

單支荷重700~800Kgf
Load Capacity 700~800Kgf / each

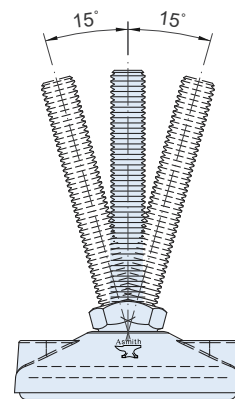
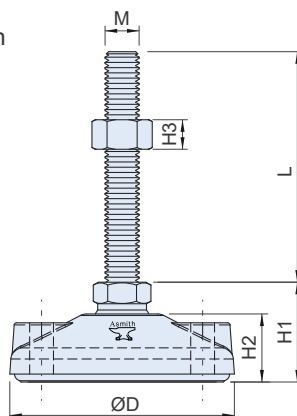
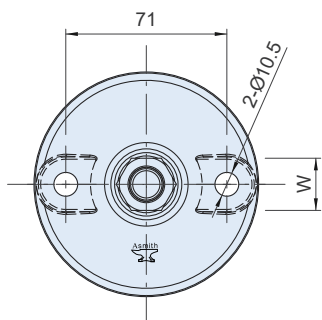

盤座開始變形值
Base starts to distort the value.

設定荷重 700 kgf 下壓值 1.5 mm · Ø100 圓腳座荷重測試曲線圖 (不含盤墊)
Suppose the leveling feet was pressuring under load capacity 700 kgf per 1.5 mm.
The chart show the leveling feet load capacity of bolt and base dimension Ø100 mm.

材質與表面處理

- 盤座：尼龍(PA66+GF) · 黑色。
- 螺桿：DK-05 合金鋼(SCM) · 鍍鋅。
DS-05 不銹鋼(SUS304)。
- 盤墊：橡膠(NBR) · 耐油、耐鹼、耐熱130°C。

特徵

- 機械安裝時，地面傾斜自動導正水平。
- 鬆緊度適中。
- 防震、防銹(DS系列)、耐鹼、防滑、耐磨耗、耐油。

MATERIAL AND FINISH

- Base: Nylon(PA66+GF), Black.
- Bolt: DK-05: Steel (SCM), Zinc plated.
DS-05: Stainless steel (SUS304).
- Cushion: Rubber (NBR), Resistance to Greasiness, Alkali, Heat 130°C.

FEATURES

- The rake of bolt's bottom and base's hole design is to prevent vibration while they are assembled.
- The loose allowance is moderate.
- Resistance to conductance rust (DS Series), shock, alkali, slip, abrasion and greasiness.

SPECIFICATIONS:

Unit:mm

| 產品編號 Item No. | Item No. | 尺寸 Dimensions | | | | | | | 荷重 Load Capacity (kgf) | 重量 Weight(g) | | | | |
|---------------|-------------|---------------|------|-----|------|------|----|----|------------------------|--------------|--------|-----|-----|-----|
| | | M | L | ØD | H1 | H2 | H3 | W | | SCM | SUS304 | | | |
| DK-0516100N | DS-0516100N | M16*P2.0 | 100 | 100 | 46.4 | 30.5 | 13 | 24 | 700 | 410 | 419 | | | |
| DK-0516150N | DS-0516150N | | 150 | | | | | | | 475 | 483 | | | |
| DK-0520100N | DS-0520100N | 100 | 48.4 | | | | | | | 16 | 30 | 800 | 544 | 543 |
| DK-0520150N | DS-0520150N | 150 | | | | | | | | | | | 644 | 648 |
| DK-0520200N | | 200 | | 744 | | | | | | | | | | |