

BALLS

Acetal resin based (POM) technopolymer, white colour.

BALL HOLDER

Polyamide based (PA) technopolymer, black colour.

FEATURES AND APPLICATIONS

- The ball elements, suitably fixed within the RLT-AL aluminum profiles (Fig. 1) create modular roller tracks for idle omnidirectional handling.
- The ball elements can be combined with RLT-U roller elements for various applications in different fields: feeding and discharging benches in construction machinery, storage and picking systems, packaging machinery, etc.
- The low friction coefficient between the ball and the ball holder eliminates the need for lubrication maintenance.
- The particular section of RLT-AL profile allows the fixing of the ball elements into the profile without the need for screws or other fasteners (Fig.1).
- The ball elements are divisible in correspondence of predefined sections (Fig.2) so as to create roller tracks of the precise required length.
- The balls may be removed and replaced without disassembling the entire roller track, by using a common screwdriver in the appropriate notch cut into the ball holder (Fig. 3).

TECHNICAL DATA

See: ELEROLL Modular roller tracks (on page 745).



FMA design

ele:roll

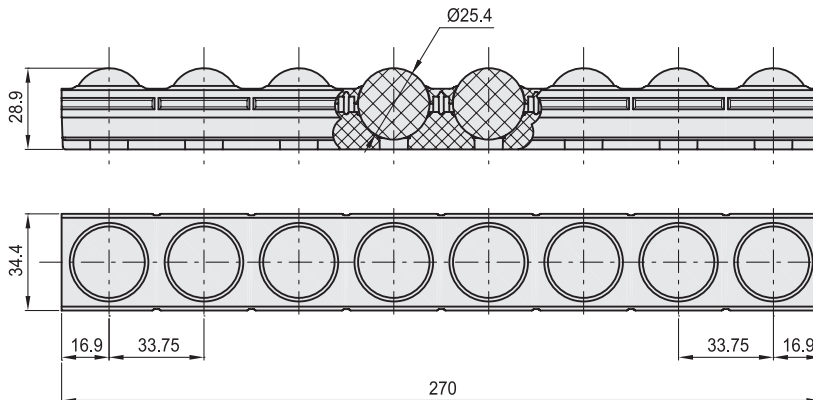
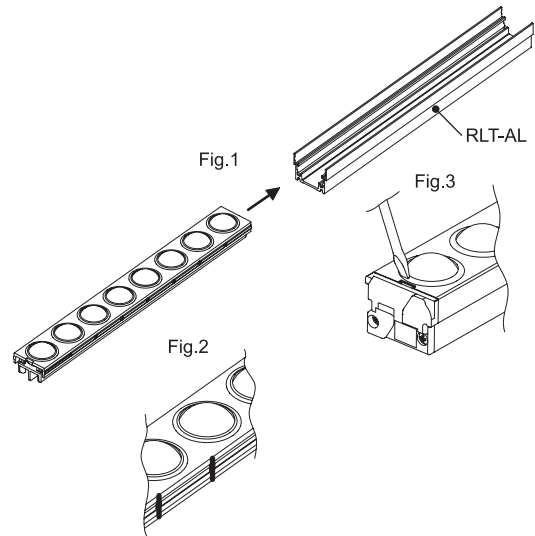

Code	Description	
429801	RLS-U-POM	151

- 1 
- 2 
- 3 
- 4 
- 5 
- 6 
- 7 
- 8 
- 9 
- 10 
- 11 
- 12 
- 13 
- 14 
- 15 
- RH 
- 