

# 偏芯半月型腳架 M / MS 系列

適用範圍：輸送機械設備、無塵室圍籬

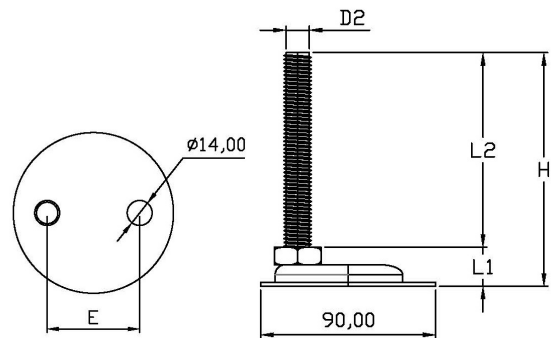

單位：mm

產品編號	螺絲材質	底座材質	D1	L1	D2	L2	E	H	荷重 (Kg)						
M9012075	鍍鋅	鍍鋅	90	21	M12 X P1.75	75	50	96	200						
M9012100						100		121							
M9012150						150		171							
M9016080				25	M16 X P2.0	90	25	M16 X P2.0	80	50	105	300			
M9016100									100		125				
M9016130									130		155				
M9016150									150		175				
M9016180									180		205				
M9016200				200	225										
M904100				不鏽鋼 304	不鏽鋼 304	90	21	1/2"—12WT	100	50	121	200			
M904150									150		171				
M905100							26	5/8"—11WT	90	26	5/8"—11WT	100	50	126	300
M905150												150		176	
MS9012050	不鏽鋼 304	不鏽鋼 304	90									21		M12 X P1.75	
MS9012075				75	96										
MS9012100				100	121										
MS9012150				150	171										
MS9016080				25	M16 X P2.0	90	25	M16 X P2.0	80	50	105	300			
MS9016100									100		125				
MS9016130									130		155				
MS9016150									150		175				
MS9016180									180		205				
MS9016200				200	225										
MS904050				不鏽鋼 304	不鏽鋼 304	90	21	1/2"—12WT	50	50	71	200			
MS904075									75		96				
MS904100							26	5/8"—11WT	90	26	5/8"—11WT	100	50	121	300
MS905100	126														
MS905150	150	176													