

Index Bolts • with mounting flange EH 22120.

Product Description

Index bolts are used for indexing purposes.
Plastic cover for grip allows better handling.



Material

Body

- Steel, blackened

Locking pin

- Steel, nitrided, black

Plastic cap

- Thermoplastic, black, dull

Assembly

Right and left mounting is possible due to countersinks on both sides.
Index bolt for lateral fastening.

Operation

By turning the index bolt 180° the locking pin will be pulled-in and secured by a notched catch (when locking pin should not overhang).

More information

Further products

- Locating Bushings, for index bolts and index plungers

Drawing

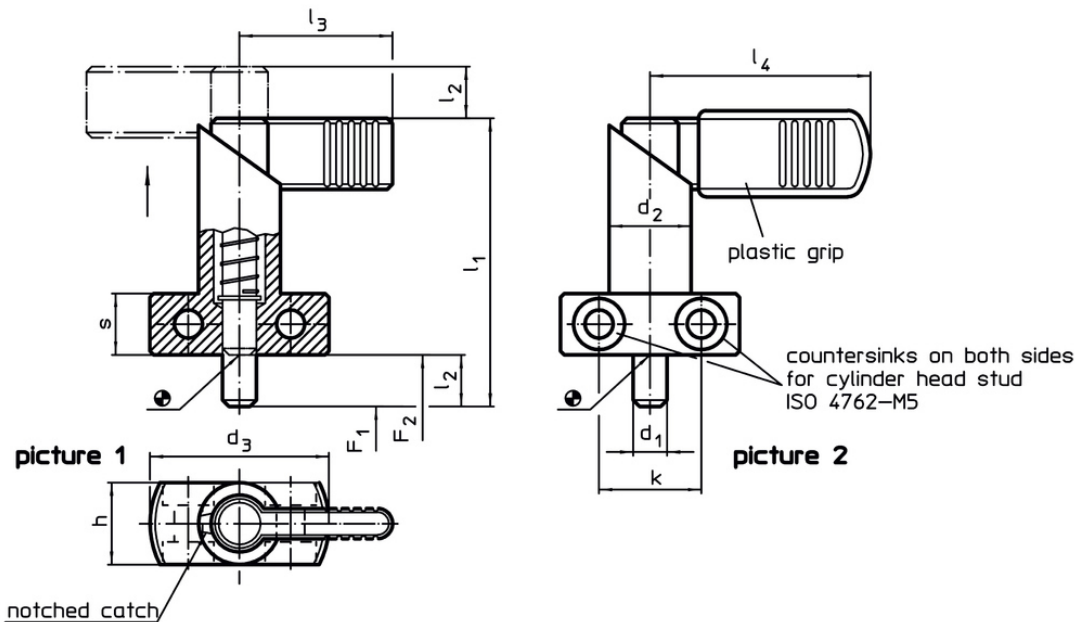

Order information

Dimensions										Spring load ¹⁾		Temperature		Weight [g]	Art. No.						
d ₁	l ₂	d ₂	d ₃	h	k	l ₁	l ₃	l ₄	s	F ₁	F ₂	min.	max.			[g]					
0 -0.05										~	~										
[mm]																[N]		[°C]			
without plastic cover for grip – picture 1																					
6	10	16	35	16	20	56	32	–	12	12	32	–	250	82	22120.0376						
8	10	16	35	16	20	56	32	–	12	12	32	–	250	85	22120.0378						
8	12	20	40	20	22	69	37	–	15	21	58	–	250	163	22120.0379						
10	10	16	35	16	20	56	32	–	12	12	32	–	250	85	22120.0381						
10	12	20	40	20	22	69	37	–	15	21	58	–	250	171	22120.0382						
12	12	20	40	20	22	69	37	–	15	21	58	–	250	174	22120.0384						

¹⁾ statistical average value