

SDS-200, SDS-201

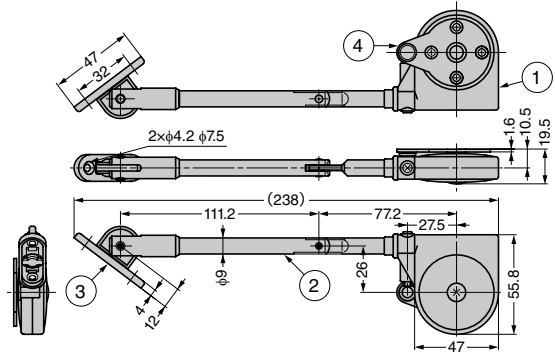

SDS-210

No.	Part Name	Material	Finish/Colour
①	Body	ABS	White, Grey, Umber
②	Arm	Steel (SPCC)	Nickel
③	Arm Mounting Plate		
④	Mounting Plate		

**[Installation SDS-200 and SDS-201]**

Right side installation for top-opening 70°. Left side installation is symmetrical.

Comes down slowly and softly in closing direction. Installation with piano/butt hinge or concealed hinge shown below.

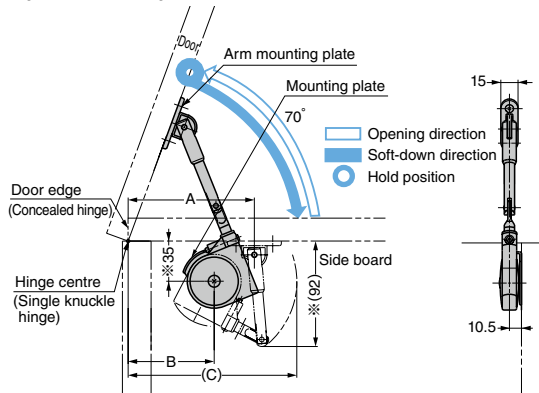

- Installation dimensions vary depending on hinge type. Reference point of installation dimension (A, B, C) : hinge centre for piano/butt hinge, while door edge for concealed hinge.
- Reference point of ※ marked dimensions is the back side of door.

**[Installation SDS-210]**

Right side installation for top-opening 105°. Left side installation is symmetrical.

Comes down slowly and softly in closing direction. Installation with piano/butt hinge or concealed hinge shown below.

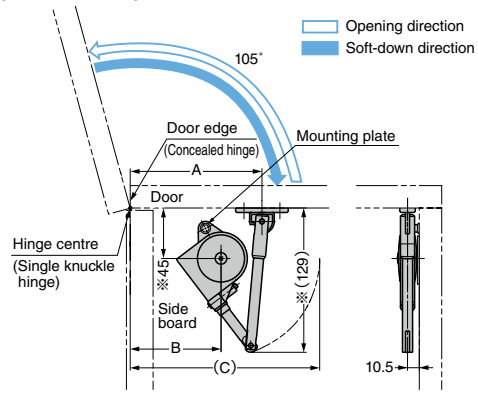

**[Full Overlay]**

Item Name	Hinge Type	Opening Angle	A	B	C
SDS-200	Single knuckle hinge	70°	110	75	147
SDS-201	Concealed Hinge 360-26/19T		109	74	146
SDS-210	Single knuckle hinge	105°	117.5	81	169
	Concealed Hinge 360-26/19T		123.5	87	175

**[Inset (Door Thickness 20mm)]**

Item Name	Hinge Type	Opening Angle	A	B	C
SDS-200	Single knuckle hinge	70°	98.5	63.5	135
SDS-201	Concealed Hinge 360-26/OT		114	79	151
SDS-210	Single knuckle hinge	105°	108.3	70	157.3

**[Body]**

RHS	CAD	Item Code	Item Name	Material	Finish/Colour	Maximum Door Moment (N·m/pc)	Maximum Door Moment (kgf·cm/pc)	Weight (g)	Box (pcs)	Carton (pcs)
		180-100-268	SDS-200-W	ABS/Steel	Nickel/Grey	3.43-4.9	35-50	153	20	100
		180-100-269	SDS-200-G		Nickel/Umber				20	100
		180-100-270	SDS-200-U		Nickel/White				20	100
		180-100-271	SDS-201-W		Nickel/Grey				20	100
		180-100-272	SDS-201-G		Nickel/Umber				20	100
		180-100-273	SDS-201-U		Nickel/White				20	100
		180-100-274	SDS-210-W		Nickel/Grey				20	100
		180-100-275	SDS-210-G		Nickel/Umber				20	100
		180-100-276	SDS-210-U		Nickel/White				20	100

**[SDS Face Plate and Spacer for Glass Door] Sold Separately**

RHS	CAD	Item Code	Item Name	Material	Finish/Colour	Weight (g)	Box (pcs)	Carton (pcs)
		180-100-260	SDS-50G-CR	Zinc Alloy (ZDC)/ABS	Chrome/Black	25	50	200
		180-928-046	SDS-50G-BL		Black Enamel Finish/Black		50	200

Refer to : P.369

LIFT ASSIST STAYS

SOFT CLOSING STAYS

TORQUE STAYS

HEAVY DUTY LOCKING STAYS

FOOT STAYS

LID STAYS

OTHER STAYS

TOP-OPENING

DOWNWARD-OPENING

UPWARD-OPENING

BOTTOM-OPENING

SWING DOOR

LIFT-UP

LIFT-DOWN

UP & OVER

BI-FOLDING

OVER THE TOP