

MAGNETIC CATCH MC-YN015S, MC-YN015SP

SUS



MC-YN015S (Magnetic catch)

MC-YN015SP (Magnetic catch, counter plate and screws)

[Cut Out Dimensions and Installation Example] For M3 screw

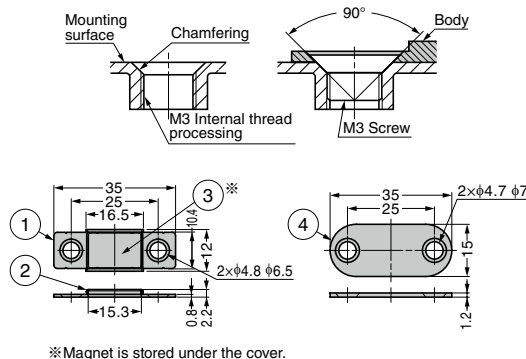

※ Magnet is stored under the cover.

- Ultra thin magnetic catch of 2.2mm thick ideal for tight space.
- Stainless steel type of the same size as conventional MC-YN001 1.
- Anti rust: made of stainless steel and acrylic resin coated magnet.
- Small body with strong magnetic force by using neodymium magnet.
- Magnetic catch only or set including magnetic catch, counter plate and screws available.
- Installation with rivet is also possible.

[Remarks]

- Be sure to read the "Cautions" 2.
- Rust may occur when using in direct water exposure or high temperature and high humidity environment.
- Max. temperature: 80°C
- The counter plate should be in contact with the yokes on both sides and should not be in contact directly with the cover. Direct contact may break the magnet.
- Be sure to chamfer the mounting surface for screws and rivets. In this way, screw head will not project when the body is fixed (refer to "Cut Out Dimensions and Installation Example").

[Parts Included]

For MC-YN015SP only

- Counter plate
- Countersunk head tapping screw 3×14 (SUS)

[Recommended Screws]

- Countersunk head screw M3 or Countersunk head wood screw nominal 3.1

No.	Part Name	Material	Finish
①	Yoke	Stainless Steel (Equivalent)	Barrel Polished
②	Cover	Stainless Steel (SUS304)	Plain
③	Magnet	Neodymium	Plastic Coating
④	Counter Plate	Stainless Steel (Equivalent)	Barrel Polished

RoHS	CAD	Item Code	Item Name	Type	Magnetic Force N	Magnetic Force kgf	Weight (g)	Box (pcs)	Carton (pcs)
☑	☑	140-020-672	MC-YN015S	Magnetic Catch Only	22.5	2.3	3.6	100	2000
☑	☑	140-020-673	MC-YN015SP	Magnetic catch · Counter Plate & Screws			7.3	100	2000

Refer to 1 : P.442, 2 : P.431

MAGNETIC CATCH MC-YN016HP

SUS



MC-YN016HP (Magnetic catch)

MC-YN016HPP (Magnetic catch, counter plate and screws)

[Cut Out Dimensions and Installation Example] For M3 screw

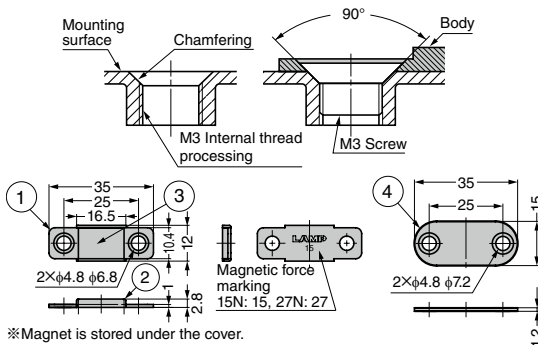

※ Magnet is stored under the cover.

- Suitable for high temperature environments up to 250°C .
- Anti rust: made of stainless steel.
- Ultra thin magnetic catch of 2.8mm thick ideal for tight spaces.
- Small body with strong magnetic force (samarium cobalt magnet).
- Magnetic catch only or set including magnetic catch, counter plate and screws available.
- Installation with rivet is also possible.
- Non-heat resistance type MC-YN015S 1 of the same shape also available.

[Remarks]

- Be sure to read the "Cautions" 2.
- The counter plate should be in contact with the yokes on both sides and should not be in contact directly with the cover. Direct contact may break the magnet.
- Be sure to chamfer the mounting surface for screws and rivets. In this way, screw head will not project when the body is fixed (refer to "Cut Out Dimensions and Installation Example").

[Parts Included]

For MC-YN016HPP only

- Counter plate
- Countersunk head tapping screw 3×14 (SUS)

[Recommended Screws]

- Countersunk head screw M3 or Countersunk head wood screw nominal 3.1

No.	Part Name	Material	Finish
①	Yoke	Stainless Steel (SUS430)	Barrel Polished
②	Cover	Stainless Steel (SUS304)	Plain
③	Magnet	Samarium Cobalt	
④	Counter Plate	Stainless Steel (SUS430)	Barrel Polished

RoHS	CAD	Item Code	Item Name	Type	Magnetic Force N	Magnetic Force kgf	Weight (g)	Box (pcs)	Carton (pcs)
☑	☑	140-033-220	MC-YN016HP-15	Magnetic Catch Only	15	1.5	4	100	2000
☑	☑	140-033-221	MC-YN016HPP-15	Magnetic Catch · Counter Plate & Screws			10.4	100	2000
☑	☑	140-033-222	MC-YN016HP-27	Magnetic Catch Only	27	2.8	5	100	2000
☑	☑	140-033-223	MC-YN016HPP-27	Magnetic Catch · Counter Plate & Screws			11.4	100	2000

Refer to 1 : P.441, 2 : P.431