

SEALED MAGNETIC CATCH MC-JM50 For Clean Room

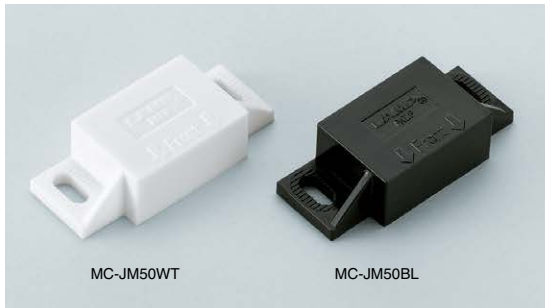

- Resin coated body prevents rusting.
- Ideal for clean rooms by using with the counter plate MC-JM49 (sold separately).
- AS parts set (below) for installing to aluminium frame also available.

[Applications]

- Washing machine, kitchen equipment, etc.

[Remarks]

- Be sure to read the "Cautions" **1**.
- Do not use in contact with steam, hot water and water. Do not leave strongly acidic or basic detergents to avoid deteriorating.
- Max. temperature: 80°C

[Sold Separately]

- Counter plate MC-JM49 **2**

[Recommended Screws]

- M4 screw, tapping screw nominal 4 (truss or binding head, SUS)

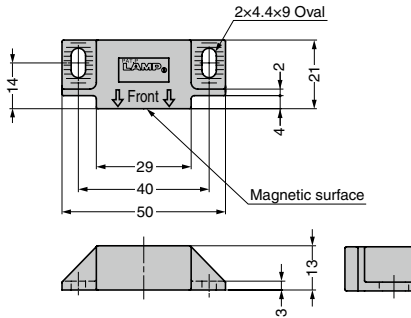

[Body]

RtHS	CAD	Item Code	Item Name	Colour	Magnetic Force N	Magnetic Force kgf	Weight (g)	Box (pcs)	Carton (pcs)
		140-050-156	MC-JM50WT	White	29.4	3	21	24	480
		140-050-155	MC-JM50BL	Black					

[Counter Plate] Sold Separately

RtHS	CAD	Item Code	Item Name	Weight (g)	Box (pcs)	Carton (pcs)
		140-050-149	MC-JM49	10	100	1000

Refer to **1** : P.431, **2** : P.464

AS Parts Set for Installing to Aluminium Frame Please refer to the series introduction page **1** for details about AS series.

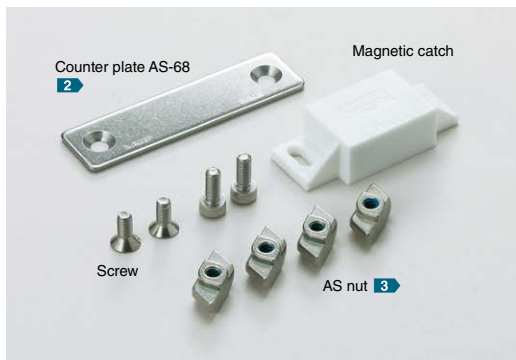

[Installation]

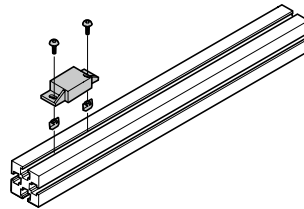

[Dimensions]

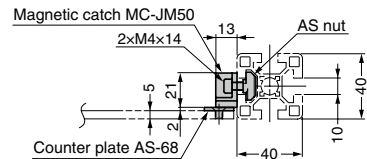
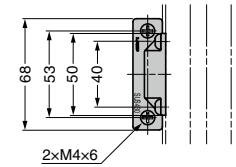

[AS Parts Set] Parts set of screws, AS nuts and counter plate used for installing to aluminium frame

RtHS	CAD	Item Code	Item Name	Aluminium Frame	Parts	Weight (set)
	-	140-041-507	AS-MC-JM50WT-40-10	40 × 40 Groove Width 10 mm	Magnetic Catch MC-JM50 : 1 pc AS Nut AS-10M4 : 2 pcs	54
	-	140-041-508	AS-MC-JM50BL-40-10		M4 × 14 Hexagon Socket Head Cap Screw : 2 pcs Counter Plate AS-68 : 1 pc	54

Refer to **1** : P.20, **2** : P.464, **3** : P.526