

MINI GUIDE SCRL2

LOAD CAPACITY 177~235 N/pair

L=R

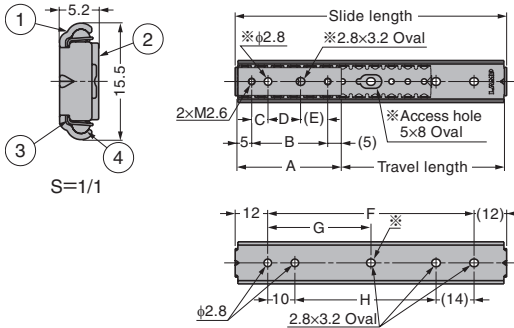
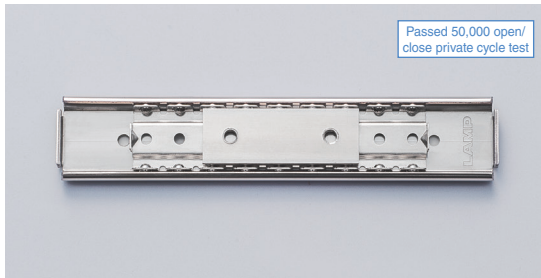

- Only 15.5mm in height with small deflection, suitable for various places.

[Remarks]

- Types with slide length 80mm have no holes marked with ※.
- Install stopper separately to protect rails and retainers from strong shock.

[Recommended Screws]

- M2.6 low head screw (for outer member)
- M2.6 screw (for inner member) Screw length = Panel thickness + Max. 1.5 mm

No.	Part Name	Material
①	Outer Member	Stainless Steel (SUS304)
②	Inner Member	
③	Retainer	
④	Balls	Steel (SUJ)

Sold by piece.

RoHS	CAD	Item Code	Item Name	Slide Length	Travel Length	A	B	C	D	E	F	G	H	Vertical Installation		Weight (g/pc)	Box (pcs)	Carton (pcs)
														Load Capacity N/pair	Load Capacity kgf/pair			
☑	3D	190-026-623	SCRL2-15-80A	80	49	28	18	-	-	-	56	-	32	177	18	16	200	400
☑	3D	190-026-624	SCRL2-15-100A	100	59	38	28	6	12	10	76	38	52	206	21	20	200	400
☑	3D	190-026-625	SCRL2-15-150A	150	109	38	28	6	12	10	126	63	102	206	21	29	100	200
☑	3D	190-026-626	SCRL2-15-200A	200	149	48	38	10	14	14	176	88	152	235	24	38	100	200

ALL STAINLESS STEEL MINI GUIDE SCRL2-15S

LOAD CAPACITY 177~235 N/pair

L=R SUS

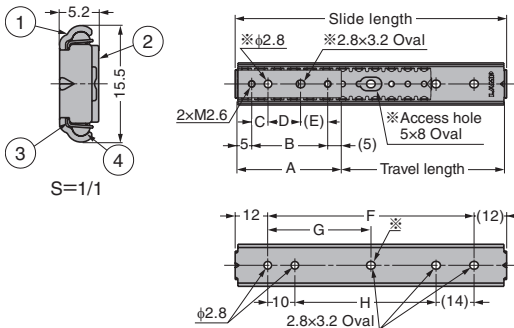
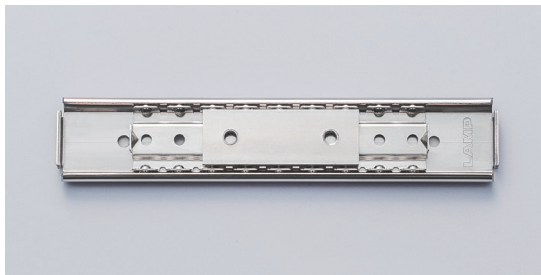

- Only 15.5mm in height with small deflection, suitable for various places.
- Grease (NSF H1 Registered Food Grade Lubricants) for food machinery is used.

[Remarks]

- Types with slide length 80mm have no holes marked with ※.
- Install stopper separately to protect rails and retainers from strong shock.

[Recommended Screws]

- M2.6 low head screw (for outer member)
- M2.6 screw (for inner member) Screw length = Panel thickness + Max. 1.5 mm

No.	Part Name	Material
①	Outer Member	Stainless Steel (SUS304)
②	Inner Member	
③	Retainer	
④	Balls	Stainless Steel (SUS440)

Sold by piece.

RoHS	CAD	Item Code	Item Name	Slide Length	Travel Length	A	B	C	D	E	F	G	H	Vertical Installation		Weight (g/pc)	Box (pcs)	Carton (pcs)
														Load Capacity N/pair	Load Capacity kgf/pair			
☑	3D	190-034-809	SCRL2-15S-80A	80	49	28	18	-	-	-	56	-	32	177	18	16	-	-
☑	3D	190-034-810	SCRL2-15S-100A	100	59	38	28	6	12	10	76	38	52	206	21	20	-	-
☑	3D	190-034-811	SCRL2-15S-150A	150	109	38	28	6	12	10	126	63	102	206	21	29	-	-
☑	3D	190-034-812	SCRL2-15S-200A	200	149	48	38	10	14	14	176	88	152	235	24	38	-	-