

FULL EXTENSION SLIDE SNS35W

LOAD CAPACITY 355~623 N/pair

L=R

DETACH

HOLD OPENED

SUS

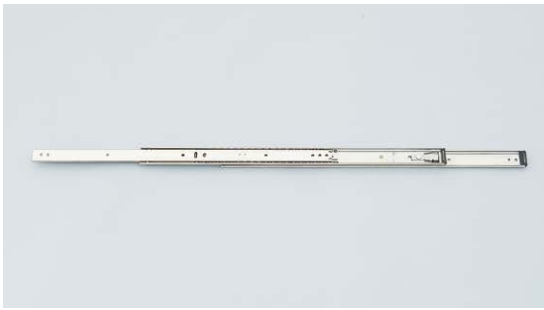

- Full extension (3 members).
- The drawer is detachable by lifting the lever.
- The drawer can be held in fully opened position.

[Remarks]

- Be sure to read the "Cautions"
- Some parts of this product are made of plastic.

[Recommended Screws]

- M4 pan head screw or nominal 4 pan head tapping screw

SOFT-CLOSE SLIDES

PUSH-TO-OPEN SLIDES

MINI SLIDES

MEDIUM SIZE SLIDES (STAINLESS STEEL)

MEDIUM SIZE SLIDES (ALUMINIUM)

MEDIUM SIZE SLIDES (OTHERS)

LINEAR SLIDES

STAINLESS STEEL

ALUMINIUM

STEEL

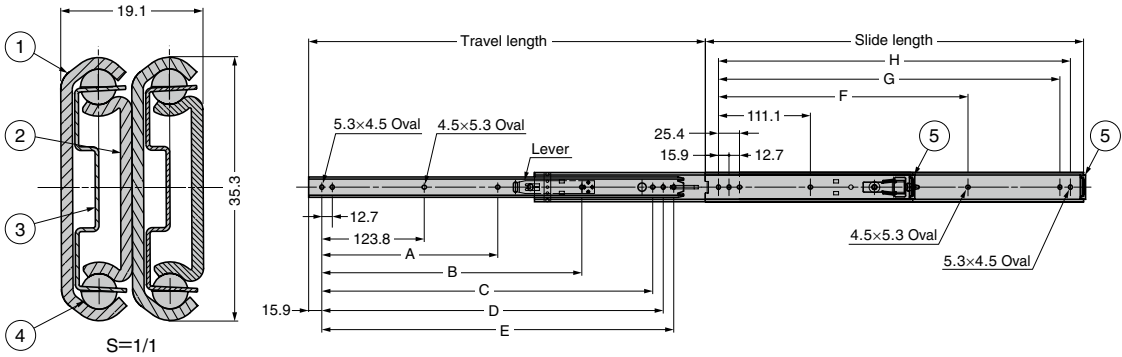

No.	Part Name	Material	Finish / Colour
①	Outer Member	Stainless Steel (SUS304)	Plain
②	Inner Member		
③	Retainer		
④	Balls	Stainless Steel (SUS440)	-
⑤	Bumper	Elastomer (TPE)	Black

Sold by piece.

R#S	CAD	Item Code	Item Name	Slide Length	Travel Length	A	B	C	D	E	F	G	H	Load Capacity N/pair	Load Capacity kgf/pair	Weight (kg/pc)	Box (pcs)	Carton (pcs)
		190-112-231	SNS35W-30	304.8	327.2	-	-	-	260.3	273	-	260.3	273	623	64	0.78	10	-
		190-112-232	SNS35W-35	355.6	377.9	-	-	298.4	311.1	323.8	-	311.1	323.8	586	60	0.903	10	-
		190-112-233	SNS35W-40	406.4	428.7	-	-	349.2	361.9	374.6	250.8	361.9	374.6	555	57	1.028	10	-
		190-112-234	SNS35W-45	457.2	479.5	212.7	400	412.7	425.4	301.6	412.7	425.4	516	53	1.151	10	-	
		190-112-235	SNS35W-50	508	530.3	238.1	365.1	450.8	463.6	476.2	352.4	463.6	476.2	475	48	1.275	10	-
		190-112-236	SNS35W-55	558.8	581.2	263.5	415.9	501.6	514.3	527	403.2	514.3	527	444	45	1.399	10	-
		190-112-237	SNS35W-60	609.6	631.9	288.9	466.7	552.4	565.1	577.8	454	565.1	577.8	413	42	1.523	10	-
		190-112-238	SNS35W-65	660.4	682.7	314.3	517.5	603.2	615.9	628.6	504.8	615.9	628.6	382	39	1.647	10	-
		190-112-239	SNS35W-70	711.2	733.5	339.7	568.3	654	666.7	679.4	555.6	666.7	679.4	355	36	1.77	10	-

Refer to : P.549